

Pressure sensor

For precision measurements

Model P-30, P-31

WIKA data sheet PE 81.54



for further approvals
see page 6



CANopen
certified
CIA201106-301V402/20-0136

Applications

- Measurement and test benches
- Calibration technology
- Laboratories
- Plant construction and machine building

Special features

- Accuracy 0.1 %, without additional temperature error in a range of 10 ... 60 °C [10 ... 140 °F]
- Optional accuracy of 0.05 % (full scale) available
- Fast measuring rates up to 1 kHz
- Analogue, USB and CANopen output signals available
- On-site calibration possible using product software



Fig. left: Process connection with pressure channel
Fig. right: Flush process connection

Description

Precise

The model P-30 and P-31 pressure sensors have been developed for precision measurements and guarantee precision measurements with a maximum measuring deviation of as low as 0.05 % of span. As a result of their active temperature compensation, these pressure sensors have no additional temperature error in the range of 10 ... 60 °C [10 ... 140 °F].

Fast

The high measuring and output rates of up to 1 kHz make the measured value available as quickly as possible.

Compact

The compact design makes the pressure sensor ideal for mounting into test benches, such as 19" racks.

Versatile

The models P-30 and P-31 offer a wide selection of electrical connections, process connections and measuring ranges, as well as a large number of different output signals. In addition to the standard analogue signals, USB and CANopen versions are also available.

Via a USB service interface and the WIKA configuration software "EasyCom", the models P-30 and P-31 can quickly and easily be adjusted on site.

Thanks to the simple-to-use software "Wika data logger", the USB version can also be used to save measured values and create customised reports.

Measuring ranges

Relative pressure							
bar	0 ... 0.25	0 ... 0.4	0 ... 0.6	0 ... 1	0 ... 1.6	0 ... 2.5	0 ... 4
	0 ... 6	0 ... 10	0 ... 16	0 ... 25	0 ... 40	0 ... 60	0 ... 100
	0 ... 160	0 ... 250	0 ... 400	0 ... 600	0 ... 1,000 ¹⁾		
psi	0 ... 5	0 ... 10	0 ... 15	0 ... 25	0 ... 30	0 ... 50	0 ... 100
	0 ... 160	0 ... 200	0 ... 300	0 ... 500	0 ... 1,000	0 ... 1,500	0 ... 2,000
	0 ... 3,000	0 ... 5,000	0 ... 10,000				

1) not available for model P-31

Absolute pressure							
bar	0 ... 0.25 ²⁾	0 ... 0.4	0 ... 0.6	0 ... 1	0.8 ... 1.2 ²⁾	0 ... 1.6	0 ... 2.5
	0 ... 4	0 ... 6	0 ... 10	0 ... 16	0 ... 25		
psi	0 ... 5	0 ... 10	0 ... 15	0 ... 25	0 ... 30	0 ... 50	0 ... 100
	0 ... 160	0 ... 200	0 ... 300				

2) only available with an accuracy of 0.1 % of span

Vacuum and +/- measuring range					
bar	-1 ... 0	-0.6 ... 0	-0.4 ... 0	-0.25 ... 0	-1 ... +0.6
	-1 ... +1	-1 ... +1.5	-1 ... +3	-1 ... +5	-1 ... +9
	-1 ... +15				
psi	-30 inHg ... 0	-30 inHg ... +15	-30 inHg ... +30	-30 inHg ... +50	-30 inHg ... +100
	-30 inHg ... +160	-30 inHg ... +200			

The given measuring ranges are also available in mbar, kg/cm² and MPa.

Other measuring ranges on request

Overload safety

The overload safety is based on the sensor element used. Depending on the selected process connection and sealing, restrictions in overload safety can result.

A higher overload safety will result in a higher temperature error.

Measuring ranges ≤ 25 bar [≤ 400 psi]: 3-fold

Measuring ranges 40 ... 600 bar [500 ... 5,000 psi]: 2-fold¹⁾

Measuring range 1,000 bar: 1.15-fold

1) 1.5-fold overload safety with 1,000 psi, 1,500 psi and 10,000 psi

Vacuum resistance

Yes

Output signal

Signal type	Signal
Current (2-wire)	4 ... 20 mA
Current (3-wire)	4 ... 20 mA 0 ... 20 mA
Voltage (3-wire)	DC 0 ... 10 V DC 0 ... 5 V
USB	per P-30/P-31 interface protocol
CANopen	per CiA DS404

Voltage supply

Power supply

The permissible power supply depends on the corresponding output signal.

- 4 ... 20 mA (2-wire): DC 9 ... 30 V
- 4 ... 20 mA (3-wire): DC 9 ... 30 V
- 0 ... 20 mA (3-wire): DC 9 ... 30 V
- DC 0 ... 5 V: DC 9 ... 30 V
- DC 0 ... 10 V: DC 14 ... 30 V
- USB: DC 4,5 ... 5,5 V
- CANopen: DC 9 ... 30 V

Total current consumption

The total current consumption is dependent on the respective signal type.

- Current (2-wire): max. 25 mA
- Current (3-wire): max. 45 mA
- Voltage (3-wire): max. 10 mA
- USB: 40 mA
- CANopen: 60 mA

Load

- Current (2-wire): $\leq (\text{power supply} - 9 \text{ V}) / 0,02 \text{ A}$
- Current (3-wire): $\leq (\text{power supply} - 9 \text{ V}) / 0,02 \text{ A}$
- Voltage (3-wire): $> \text{max. output signal} / 1 \text{ mA}$

Accuracy data

Accuracy at reference conditions

Accuracy	
Standard	$\leq \pm 0,1 \%$ of span
Option	$\leq \pm 0,05 \%$ of span

Including non-linearity, hysteresis, non-repeatability, zero offset and end value deviation (corresponds to measured error per IEC 61298-2). Calibrated in vertical mounting position with process connection facing downwards.

Non-linearity (per IEC 61298-2)

$\leq \pm 0.04 \%$ of span BFSL

Temperature error

In the range of $-20 \dots +80 \text{ }^\circ\text{C}$ [$-4 \dots +176 \text{ }^\circ\text{F}$] the instrument is actively compensated.

- $-20 \dots +10 \text{ }^\circ\text{C}$ [$-4 \dots +50 \text{ }^\circ\text{F}$]: $\leq \pm 0,2 \%$ of span/10 K
- $10 \dots 60 \text{ }^\circ\text{C}$ [$50 \dots 140 \text{ }^\circ\text{F}$]: no additional error ¹⁾
- $60 \dots 80 \text{ }^\circ\text{C}$ [$140 \dots 176 \text{ }^\circ\text{F}$]: $\leq \pm 0,2 \%$ of span/10 K

1) For the optional accuracy at reference conditions of $\leq \pm 0.05 \%$ of span there is an additional temperature error of $\leq \pm 0.05 \%$ of span.

Total error band ($10 \dots 60 \text{ }^\circ\text{C}$) [$50 \dots 140 \text{ }^\circ\text{F}$]

$\leq \pm 0.1 \%$ of span

Long-term stability

$\leq \pm 0.1 \%$ of span/year

Adjustability

Adjustment via the "EasyCom 2011" or "EasyCom CANopen" software

Zero point: $-5 \dots +20 \%$ of span

Span: $-20 \dots +5 \%$ of span

Measuring rate

The measuring rate is dependent on the respective signal type.

- 2-wire: 2 ms
- 3-wire: 1 ms
- USB: 3 ms
- CANopen: 1 ms

Reference conditions

Temperature

15 ... 25 °C [59 ... 77 °F]

Atmospheric pressure

860 ... 1,060 mbar [12.47 ... 15.37 psi]

Humidity

45 ... 75 % relative

Power supply

- DC 24 V
- DC 5 V with USB version

Warm-up time

< 10 min

Mounting position

Process connection lower mount (LM)

Operating conditions

Ingress protection (per IEC/EN 60529)

The ingress protection depends on the type of electrical connection.

- Angular connector DIN 175301-803 A: IP65
- Circular connector M12 x 1 (4-pin): IP67
- Circular connector M16 x 0.75 (5-pin): IP67
- Bayonet connector: IP67
- CANopen M12 x 1 (5-pin): IP67
- USB: IP67
- Cable outlet: IP67

The stated ingress protection only applies when plugged in using mating connectors that have the appropriate ingress protection.

Vibration resistance

10 g (IEC 60068-2-6)

Shock resistance

200 g (IEC 60068-2-27, mechanical)

Service life

10 million load cycles

Free fall test

The instrument is resistant to an impact onto concrete from a height of 1 m.

Temperatures

- Ambient: -20 ... +80 °C [-4 ... +176 °F]
- Medium: -20 ... +105 °C [-4 ... +221 °F]
- Storage: -40 ... +85 °C [-40 ... +185 °F]

Electrical connections

Short-circuit resistance

- S₊ vs. U₋
- CAN-High/CAN-Low vs. U₊/U₋

Reverse polarity protection

U₊ vs. U₋

Overvoltage protection

DC 36 V (not with USB version)

Insulation voltage

DC 500 V

Connection diagrams

Circular connector M12 x 1 (4-pin)

		2-wire	3-wire
	U ₊	1	1
	U ₋	3	3
	S ₊	-	4

Angular connector DIN 175301-803 A

		2-wire	3-wire
	U ₊	1	1
	U ₋	2	2
	S ₊	-	3

Circular connector M16 x 0.75 (5-pin)

		2-wire	3-wire
	U ₊	3	3
	U ₋	1	4
	S ₊	-	1

Bayonet connector

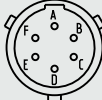
		2-wire	3-wire
	U ₊	A	A
	U ₋	B	B
	S ₊	-	C

Circular connector M12 x 1 (5-pin), CANopen

		2-wire
	U ₊	2
	U ₋	3
	Shield	1
	CAN-High	4
	CAN-Low	5

Cable outlet unshielded

		2-wire	3-wire
	U ₊	brown	brown
	U ₋	blue	blue
	S ₊	-	black

Cable lengths on request.

Process connections

Model P-30

Standard	Thread size
EN 837	G ¼ B
	G ¼ female
	G ½ B
ISO 1179-2 (formerly DIN 3852-E)	G ¼ A
ANSI/ASME B1.20.1	¼ NPT
	½ NPT
-	M18 x 1.5 male with G ¼ female
	G ½ male with G ¼ female

Other connections on request

Model P-31

Standard	Thread size
EN 837	G ½ B with flush diaphragm
	G 1 B with flush diaphragm

Sealings

Thread size	Standard	Option
G ¼ B	Without	Cu Stainless steel
G ½ B	Without	Cu Stainless steel
G ¼ A	Without	NBR FPM/FKM

For all other process connections no sealings are available.

Materials



Wetted parts

- Stainless steel
- Additionally Elgiloy for measuring ranges > 25 bar
- For sealing materials see "Process connections"

Non-wetted parts

Stainless steel

Approvals

Logo	Description	Country
	EU declaration of conformity <ul style="list-style-type: none">■ EMC directive, EN 61326 emission (group 1, class B) and interference immunity (industrial application)■ Pressure equipment directive, PS > 200 bar; module A, pressure accessory■ RoHS directive	European Union
	EAC EMC directive	Eurasian Economic Community
-	CRN Safety (e.g. electr. safety, overpressure, ...)	Canada

Certificates

- Accuracy test report (included in the delivery)
- 2.2 test report per EN 10204 ¹⁾
- 3.1 inspection certificate per EN 10204 ¹⁾

1) option

Approvals and certificates, see website

Dimensions in mm

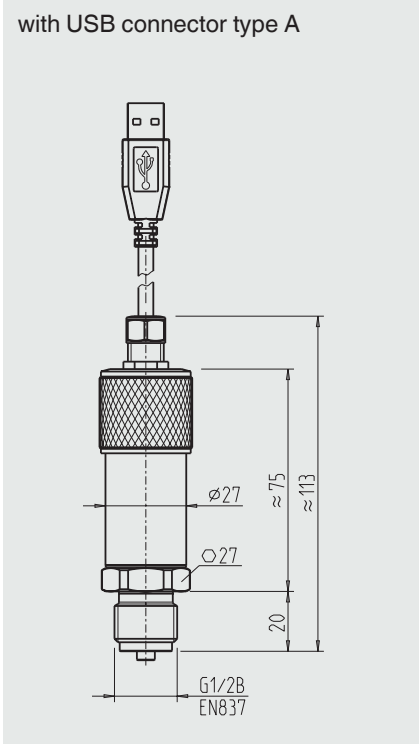
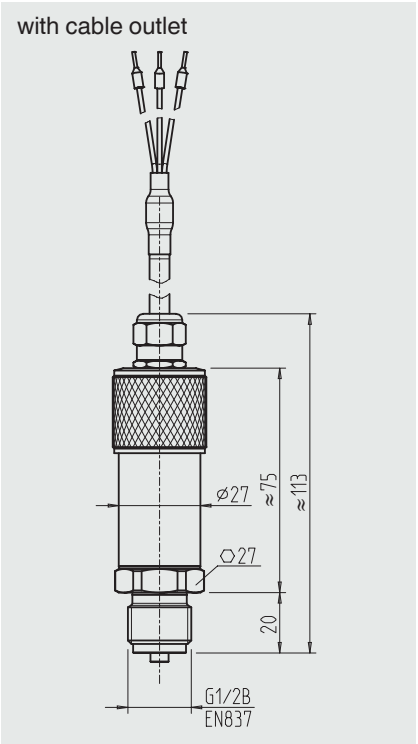
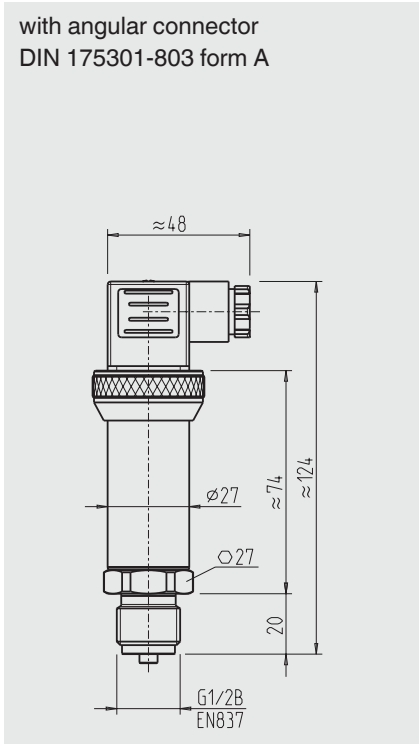
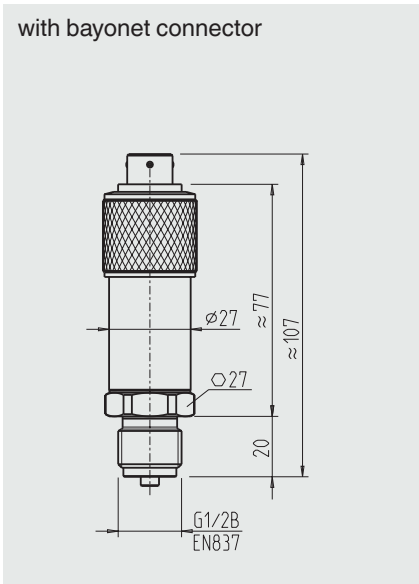
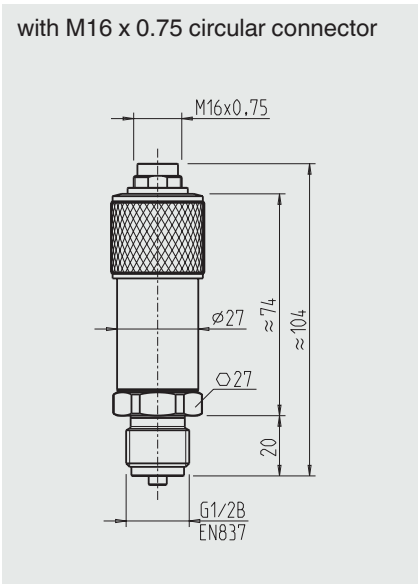
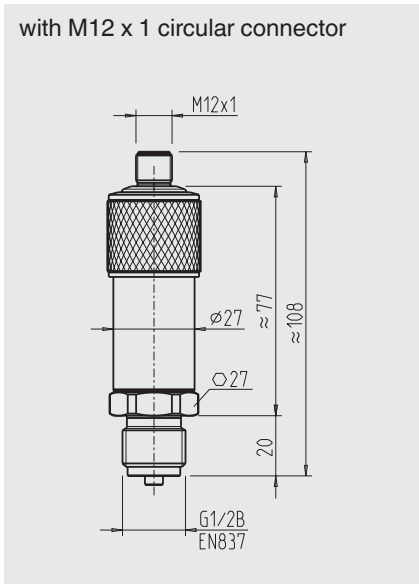

Process connections for model P-30

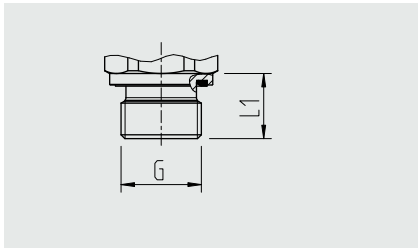

G	L1
G ¼ A DIN 3852-E	12

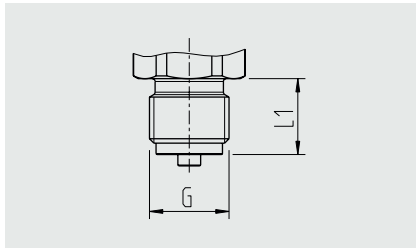

G	L1
G ¼ B EN 837	13
G ½ B EN 837	20

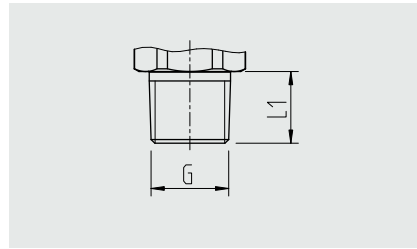

G	L1
¼ NPT	13
½ NPT	19

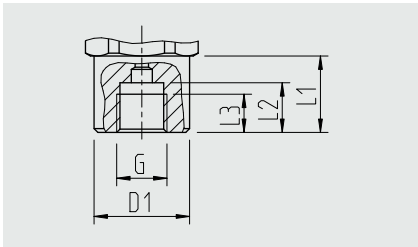

G	L1	L2	L3	D1
G ¼	20	13	10	Ø 17,5

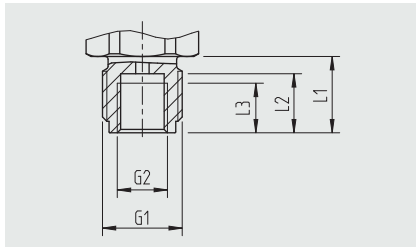

G1	G2	L1	L2	L3
G ½ B	G ¼	20	15,5	13

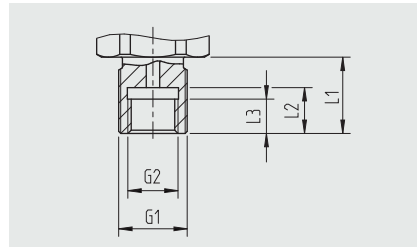

G1	G2	L1	L2	L3
M18 x 1,5	G ¼	20	12	9

Process connections for model P-31

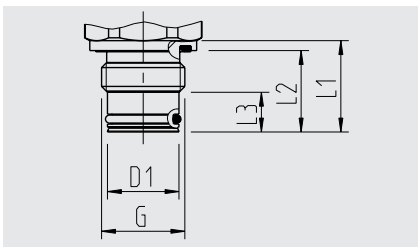

G	L1	L2	L3	D1
G ½ B	23	20,5	10	Ø 18

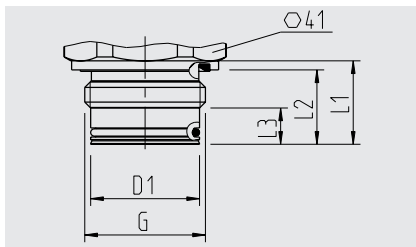

G1	L1	L2	L3	D1
G 1 B	23	20,5	10	30

Accessories

CANopen version

Designation	Order number
Y-connector (M12 x 1 female connector, male/female connector)	2344526
Terminating resistor (120 Ω , M12 x 1 connector)	2308274
Bus cable 0.5 m (M12 x 1 male/female connector)	2308240
Bus cable 2 m (M12 x 1 male/female connector)	2308258
Software EasyCom CANopen, incl. PCAN-USB adapter, cable set and power supply	7483167
P-30/P-31 software CD	11478901

Analogue version

Designation	Order number
P-30/P-31 USB service interface, incl. WIKA software CD	13193075

Software

The full software is available to download as freeware from the following path.
[www.wika.com / Download / Software / Pressure / Pressure sensors](http://www.wika.com/Download/Software/Pressure/Pressure_sensors)

Ordering information

Model / Measuring range / Output signal / Accuracy at reference conditions / Process connection / Sealing / Electrical connection

© 2009 WIKA Alexander Wiegand SE & Co. KG, all rights reserved.
The specifications given in this document represent the state of engineering at the time of publishing.
We reserve the right to make modifications to the specifications and materials.

