

# Diaphragm seal with threaded connection

## Threaded design

### Model 990.40, for low pressure ranges

WIKA data sheet DS 99.06



for further approvals  
see page 5

#### Applications

- For aggressive, hot, corrosive, environmentally hazardous or toxic media
- For mounting to measuring instruments for low pressure ranges or to differential pressure measuring instruments
- Filter monitoring
- Level measurement

#### Special features

- Process connection with thread
- Version with internal diaphragm, large working volume, diaphragm seal parts screwed together
- Large selection of process connections and materials
- Flushing connections optionally available

#### Description

Diaphragm seals are used for the protection of pressure measuring instruments in applications with difficult media. In diaphragm seal systems, the diaphragm of the diaphragm seal effects the separation of the instrument and the medium. The pressure is transmitted to the measuring instrument via the system fill fluid which is inside the diaphragm seal system.

For the implementation of demanding customer applications, there are a wide variety of designs, materials and system fill fluids available.

For further technical information on diaphragm seals and diaphragm seal systems see IN 00.06 "Application, operating principle, designs".



**Diaphragm seal with threaded connection,  
model 990.40**

The model 990.40 diaphragm seal with threaded connection in threaded design is suitable for versatile application areas. A replacement of the lower body is possible without modifications on the diaphragm seal system. With this diaphragm seal, low pressure ranges can be covered. The large diameter of the diaphragm effects a lower deviation at the measuring instrument when the temperature changes.

Mounting of the diaphragm seal to the measuring instrument may be made via a direct connection, for high temperatures via a cooling element or via a flexible capillary.

For the material selection WIKA offers a variety of solutions, in which the upper body of the diaphragm seal and the wetted parts can be made of identical or different materials. The wetted parts can, as an alternative, be coated.

## Specifications

Model 990.40	Standard	Option
<b>Pressure range</b>	0 ... 100 bar [0 ... 1,450 psi] or all other equivalent vacuum or combined pressure and vacuum ranges	
<b>Level of cleanliness of wetted parts</b>	Oil and grease free per ASTM G93-03 level F WIKA standard (< 1,000 mg/m <sup>2</sup> )	Oil and grease free per ASTM G93-03 level D and ISO 15001 (< 220 mg/m <sup>2</sup> )
<b>Origin of wetted parts</b>	International	EU, CH, USA
<b>Connection to the measuring instrument</b>	Axial adapter	Axial adapter with G ½, G ¼, ½ NPT or ¼ NPT (female)
<b>Type of mounting</b>	Direct mounting	<ul style="list-style-type: none"> <li>■ Capillary</li> <li>■ Cooling element</li> </ul>
<b>Sealing</b>	PTFE max. 260 °C [500 °F]	<ul style="list-style-type: none"> <li>■ FPM, max. 200 °C [392 °F]</li> <li>■ Statotherm®, max. 400 °C [752 °F]</li> </ul>
<b>Flushing connection</b>	-	<ul style="list-style-type: none"> <li>■ Single flushing connection (G ¼, G ⅛, ¼ NPT, ⅛ NPT)</li> <li>■ Dual flushing connection (G ¼, G ⅛, ¼ NPT, ⅛ NPT)</li> <li>■ Plug screws</li> </ul>
<b>Design per NACE</b>	-	<ul style="list-style-type: none"> <li>■ MR 0175</li> <li>■ MR 0103</li> </ul>
<b>Vacuum service (see IN 00.25)</b>	Basic service	<ul style="list-style-type: none"> <li>■ Premium service</li> <li>■ Advanced service</li> </ul>
<b>Instrument mounting bracket (only for capillary option)</b>	-	<ul style="list-style-type: none"> <li>■ Form H per DIN 16281, 100 mm, aluminium, black</li> <li>■ Form H per DIN 16281, 100 mm, stainless steel</li> <li>■ Bracket for pipe mounting, for pipe outer Ø 20 ... 80 mm, steel (see data sheet AC 09.07)</li> </ul>

### Example: Model 990.40 with mounted process transmitter

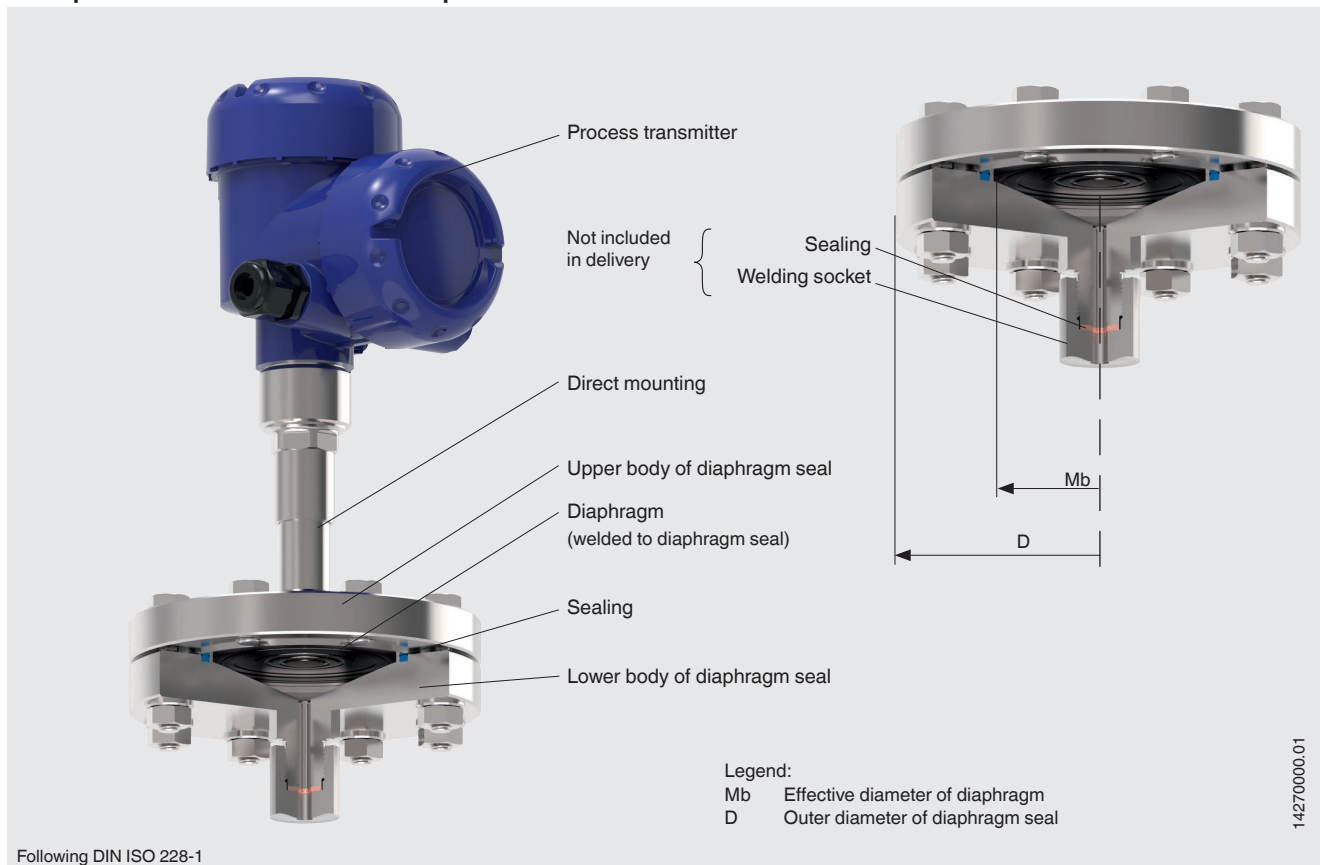

## Process connection

Standard	Male thread		Female thread	
	Standard	Option	Standard	Option
Following DIN ISO 228-1	G ½ A	G ¼ A G ⅜ A G ¾ A G 1 A G 1 ½ A	G ½	G ¼ G ⅜ G ¾ G 1
Following ASME B 1.20.1	½ NPT	¼ NPT ⅜ NPT ¾ NPT 1 NPT 1 ½ NPT	½ NPT	¼ NPT ⅜ NPT ¾ NPT 1 NPT
Following DIN 13-1	M20 x 1.5	-	M20 x 1.5	-
Following ISO 7-1	R ½	R ¼ R ⅜ R ¾	-	-

Other process connections on request

## Material combinations

Upper body of diaphragm seal	Wetted parts		Maximum permissible process temperature <sup>1)</sup> in °C [°F]
	Lower body of diaphragm seal	Diaphragm	
<b>Stainless steel 1.4404 (316L)</b>	Stainless steel 1.4404 (316L)	Stainless steel 1.4404 / 1.4435 (316L), standard version	400 [752]
	Stainless steel 1.4539 (904L)	Stainless steel 1.4539 (904L)	
	Stainless steel 1.4541 (321)	Stainless steel 1.4541 (321)	
	Stainless steel 1.4571 (316Ti)	Stainless steel 1.4571 (316Ti)	
	PTFE lining <sup>2)</sup>	ECTFE coating	150 [302]
	PTFE lining <sup>2)</sup>	PFA (perfluoroalkoxy) coating, FDA	260 [500]
	PTFE lining <sup>2)</sup>	PFA (perfluoroalkoxy) coating, antistatic	
	-	Gold plating	400 [752]
	-	Wikaramic® coating	
	Hastelloy C22 (2.4602)	Hastelloy C22 (2.4602)	260 [500]
	Hastelloy C276 (2.4819)	Hastelloy C276 (2.4819)	400 [752]
	Inconel 600 (2.4816)	Inconel 600 (2.4816)	
	Inconel 625 (2.4856)	Inconel 625 (2.4856)	
	Incoloy 825 (2.4858)	Incoloy 825 (2.4858)	
	Monel 400 (2.4360)	Monel 400 (2.4360)	
	Nickel 200 (2.4060, 2.4066)	Nickel 200 (2.4060, 2.4066)	
	Titanium class 2 (3.7035)	Titanium class 2 (3.7035)	150 [302]
Titanium class 7 (3.7235)	Titanium grade 11 (3.7225)		
Tantalum lining <sup>2)</sup>	Tantalum	300 [572]	
<b>Stainless steel 1.4435 (316L)</b>	Stainless steel 1.4435 (316L)	Stainless steel 1.4435 (316L)	400 [752]
<b>Stainless steel 1.4539 (904L)</b>	Stainless steel 1.4539 (904L)	Stainless steel 1.4539 (904L)	
<b>Stainless steel 1.4541 (321)</b>	Stainless steel 1.4541 (321)	Stainless steel 1.4541 (321)	
<b>Stainless steel 1.4571 (316Ti)</b>	Stainless steel 1.4571 (316Ti)	Stainless steel 1.4571 (316Ti)	
<b>Duplex 2205 (1.4462)</b>	Duplex 2205 (1.4462)	Duplex 2205 (1.4462)	
<b>Superduplex 2507 (1.4410)</b>	Superduplex 2507 (1.4410)	Superduplex 2507 (1.4410)	
<b>Hastelloy C22 (2.4602)</b>	Hastelloy C22 (2.4602)	Hastelloy C22 (2.4602)	400 [752]
<b>Hastelloy C276 (2.4819)</b>	Hastelloy C276 (2.4819)	Hastelloy C276 (2.4819)	
<b>Inconel 600 (2.4816)</b>	Inconel 600 (2.4816)	Inconel 600 (2.4816)	
<b>Inconel 625 (2.4856)</b>	Inconel 625 (2.4856)	Inconel 625 (2.4856)	
<b>Incoloy 825 (2.4558)</b>	Incoloy 825 (2.4858)	Incoloy 825 (2.4858)	
<b>Monel 400 (2.4360)</b>	Monel 400 (2.4360)	Monel 400 (2.4360)	
<b>Nickel 200 (2.4060, 2.4066)</b>	Nickel 200 (2.4060, 2.4066)	Nickel 200 (2.4060, 2.4066)	
<b>Titanium grade 2 (3.7035)</b>	Titanium grade 2 (3.7035)	Titanium grade 2 (3.7035)	
<b>Titanium grade 7 (3.7235)</b>	Titanium grade 7 (3.7235)	Titanium grade 11 (3.7225)	

1) The maximum permissible process temperature of the diaphragm seal system is limited by the joining method, by the system fill fluid and by the measuring instrument.

2) For G ½ and M 20 x 1.5 (male), max. 0 ... 100 bar

Further material combinations for special process temperatures on request

## Approvals

Logo	Description	Country
	<b>EAC (option)</b> Pressure equipment directive	Eurasian Economic Community
-	<b>CRN</b> Safety (e.g. electr. safety, overpressure, ...)	Canada
-	<b>MTSCHS (option)</b> Permission for commissioning	Kazakhstan

## Certificates (option)

- 2.2 test report per EN 10204 (e.g. state-of-the-art manufacturing, material proof, indication accuracy for diaphragm seal systems)
- 3.1 inspection certificate per EN 10204 (e.g. material proof for wetted metallic parts, indication accuracy for diaphragm seal systems)

Approvals and certificates, see website

## Dimensions in mm [in]

### Male thread

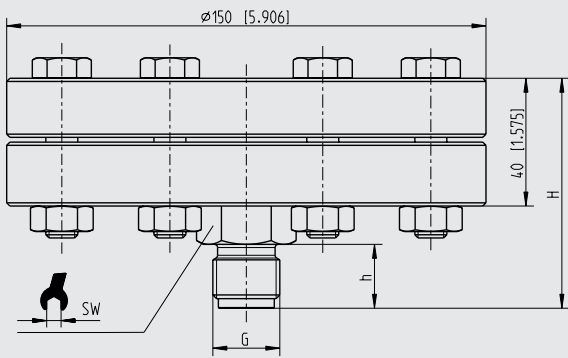

Legend:

Mb Diameter of diaphragm  
G Thread  
SW Spanner width

14038596.01

G	Dimensions in mm [in]			
	h	H	Mb	SW
G ¼ A	13 [5.512]	65 [2.559]	90 [3.543]	27 [1.063]
G ⅜ A	16 [0.63]	68 [2.677]		
G ½ A	20 [0.787]	72 [2.835]		
G ¾ A				30 [1.181]
G 1 A	28 [1.102]	80 [3.15]		36 [1.417]
G 1 ½ A				41 [1.614]
¼ NPT	13 [5.512]	65 [2.559]		27 [1.063]
⅜ NPT	15 [0.591]	67 [2.638]		
½ NPT	19 [0.748]	71 [2.798]		
¾ NPT	20 [0.787]	72 [2.835]		30 [1.181]
1 NPT	25 [0.984]	77 [3.031]	36 [1.417]	
1 ½ NPT	26 [1.024]	78 [3.071]	41 [1.614]	
M20 x 1.5	20 [0.787]	72 [2.835]	27 [1.063]	
R ¼	15 [0.591]	67 [2.638]		22 [0.866]
R ⅜	18 [0.709]			
R ½	19 [0.748]	71 [2.798]		
R ¾	20 [0.787]	72 [2.835]		27 [1.063]

### Female thread

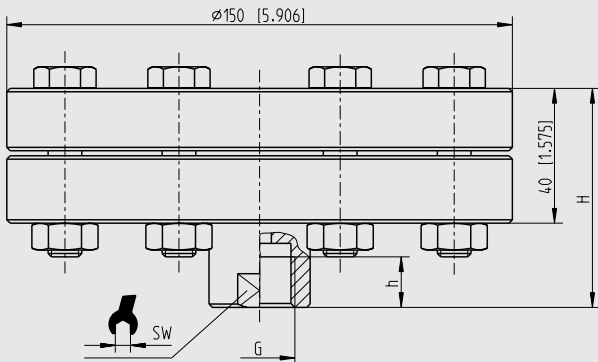

Legend:

Mb Diameter of diaphragm  
G Thread  
SW Spanner width

14277245.01

G	Dimensions in mm [in]			
	h	H	Mb	SW
G ¼	10 [0.394]	63 [2.480]	90 [3.543]	27 [1.063]
G ⅜	12 [0.472]			
G ½	14 [0.551]	65 [2.559]		
G ¾	16 [0.63]	68 [2.677]		36 [1.417]
G 1	18 [0.709]	73 [2.874]		41 [1.614]
¼ NPT	-	63 [2.480]		27 [1.614]
⅜ NPT				
½ NPT		65 [2.559]		
¾ NPT		68 [2.677]		36 [1.417]
1 NPT		73 [2.874]		41 [1.614]
M20 x 1.5	15.5 [0.61]	65 [2.559]	27 [1.063]	

## Ordering information

Diaphragm seal:

Diaphragm seal model / Process connection (process connection standard, thread, nominal pressure rating) / Material (upper body, diaphragm, lower body) / Sealing / Retainer parts (retainer flange, screws) / Flushing connection (plug screw) / Connection to the measuring instrument / Level of cleanliness of wetted parts / Origin of wetted parts / Certificates

Diaphragm seal system:

Diaphragm seal model / Process connection (process connection standard, thread, nominal pressure rating) / Material (upper body, diaphragm, lower body) / Sealing / Retainer parts (retainer flange, screws) / Flushing connection (plug screw) / Pressure measuring instrument model (per data sheet) / Mounting (direct mounting, cooling element, capillary) / min. and max. process temperature / min. and max. ambient temperature / Vacuum service / System fill fluid / Certificates / Height difference / Level of cleanliness of wetted parts / Origin of wetted parts / Instrument mounting bracket

© 05/2013 WIKA Alexander Wiegand SE & Co. KG, all rights reserved.  
The specifications given in this document represent the state of engineering at the time of publishing.  
We reserve the right to make modifications to the specifications and materials.

