

series  
**892E**  
2-Stage Servo Valve  
Rated flows up to 230 l/m

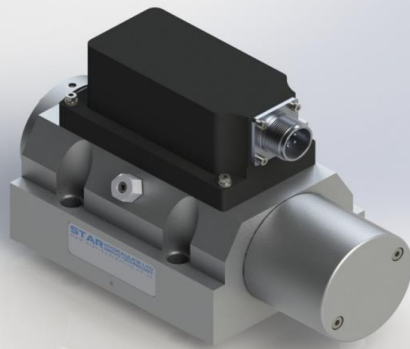

### Features

- Maximum operating pressure 315 bar
- Electric feedback at main stage spool
- ISO 10372-04-04-0-92 mounting pattern
- External pilot supply (5 port)
- Suitable for 3-way or 4-way applications
- Low hysteresis & zero point drift
- High spool drive forces
- Spool in bushing design
- Long life Sapphire Technology



Star Hydraulics Limited  
Severn Drive  
Tewkesbury Business Park  
Tewkesbury  
Gloucestershire  
GL20 8SF  
England (UK)

[www.star-hydraulics.co.uk](http://www.star-hydraulics.co.uk)

ST-892E-2016.1-En

# Benefits and Features

## Sapphire ball in slot design

- Incorporated into Star designs since 1988
- Many billions of cycles per service life
- Increased spool life due to spool rotation
- Ultra low coefficient of friction sapphire to steel
- Feedback mechanism unhindered by spool rotation
- Extended warranties available



## Safety

- Flame proof
- Intrinsic safety
- Class, Div & Zone coverage
- Mechanical failsafe
- Double & triple coil redundancy



## Quality



- Independent audit process is our commitment on quality
- Focus on customer needs and expectations
- Delivery schedules on time
- Continual improvements on products and services
- Maintaining design and manufacturing integrity

## Custom spool lap & bushing port geometries

- Zero overlap
- Overlap (closed center)
- underlap (open center)
- Dual gain
- Asymmetric gain

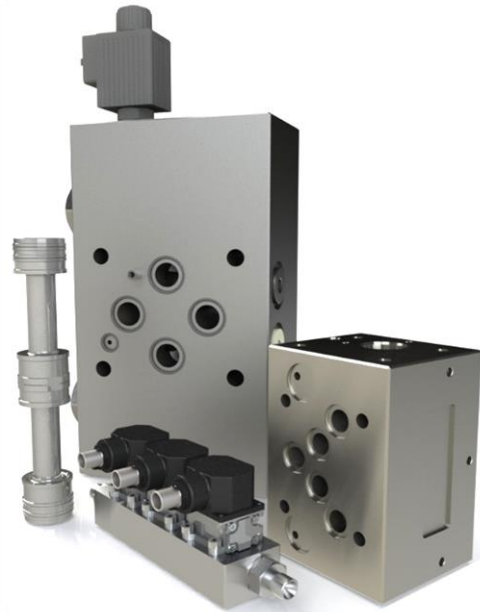
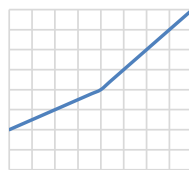
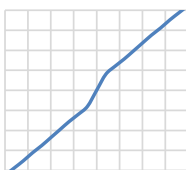
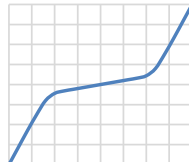
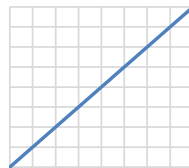

## Special projects

- Compact servo designs
- Special interfaces
- Modular components



## Sealing materials

- Nitrile
- Fluorocarbon (Viton)
- Ethylene-Propylene
- Fluorosilicone

## Sapphire flow

- Ensuring first stage stability
- Precisely matched flow properties
- Long life in extreme environments



## Special connectors

- MIL-C-5015
- MIL-DTL-38999
- Conduit style male/female
- Hermetic

## Technical data

### Hydraulic

Nominal flow ratings [ $\pm 10\%$ ]	at 70 bar $\Delta p$	95, 150, 230 l/m
Operating pressure (max)	Ports	P, C1, C2, X R
Seal material	NBR, FPM	315 bar 315 bar
Fluid viscosity range (recommended)		10 to 100 mm <sup>2</sup> /s (cSt)
Fluid type		Mineral oil to ISO 11158, DIN 51524 or equivalent MIL-H-5606 Kerosene Water glycols others on request
Filter rating (recommended)	Pressure line Off-line	Beta 10 = 200 (10 $\mu\text{m}$ abs), non by-pass & indicator Beta 2 = 1000 (2 $\mu\text{m}$ abs)
Fluid cleanliness	ISO 4406: 1999 minimum recommended	16/ 14/ 11 15/ 13/ 10

### Operational parameters

Hysteresis		$\leq 0.5\%$ without dither
Threshold		$\leq 0.1\%$ without dither
Null shift	$\Delta T$ 40°C	$\leq 2.0\%$
Internal leakage	140 bar supply (1% overlap) 95 l/m 150, 230 l/m	$\leq 2.0$ l/m $\leq 4.0$ l/m
Load pressure difference	1% input	$\geq 30\%$ of supply pressure can be as high as 100%
Response time	0-100% rated spool stroke 95, 150 l/m 230 l/m	9 ms 17 ms
Mounting pattern		ISO 10372-06-05-0-92 with X port
Mounting position		Any, fixed or movable (1)
Weight	std unit additional filter housing	3.7 kg 5.0 kg
Design protection	EN 60529	IP 65
Shipping protection		Sealed base plate
Vibration		30 g all axis, 5 Hz to 2,000 Hz
Shock		30 g all axis
Seal material options		NBR, FPM
Temperature range		-20 to 80 °C

(1) Depending on valve orientation the main stage spool may drop when supply pressure is switched off leading to unwatered startup bump. If so then an external pilot supply model (892) is suggested, this allows startup of the first stage via the X port prior to applying pressure at the main stage.

## Technical data - Electrical details

### Dual rail power supply +15/0/-15 V

Pin	Function	Values
A	Supply	+15 Vdc
B	Supply	-15 Vdc
C	GND	0 V
D	Input rated command (differential)	±10 V, ±10 mA
E	<i>Inverse bi-polar command signals</i>	
F	Actual spool position	±10 Vdc
PE	Protective earth	

### Single rail power supply 24 V

Pin	Function	Values
A	Supply	24 Vdc
B	GND	0 V
C	Not used	
D	Input rated command (differential)	±10 V, ±10 mA
E	<i>Inverse bi-polar command signals</i>	
F	Actual spool position	±10 Vdc
PE	Protective earth	

*N.B. Power supply and rated input signals are factory set, please advise preferences at time of order*

<b>Power supply</b>	Current (mA) Ripple (mV p-p) <b>Warning</b>	< 100 each rail (typically 50) < 50 +15 V or -15V rail must NOT be connected to pin C (GND)
<b>Command signal</b>	Polarity P»C2, C1»R ±10 V input ±10 mA input	D +, E - impedance 100 Kohm impedance 1 Kohm
<b>Spool position output</b>	Voltage output	Output impedance <10 ohm, min. receiver impedance 1 kohm Pin F must be referenced to 0 V
Valve connector type	MIL-C-5015	MS3102E-14-SA-7P mates with MS3106E-14-SA-7SN Consult factory for more options
Standard connector orientation	also available over	C2 port C1; please advise when ordering
Connecting cable		DEF STAN 61-12, part 4 screened, 7-2-C type, 8 core (7/0.2 mm)

## Technical data

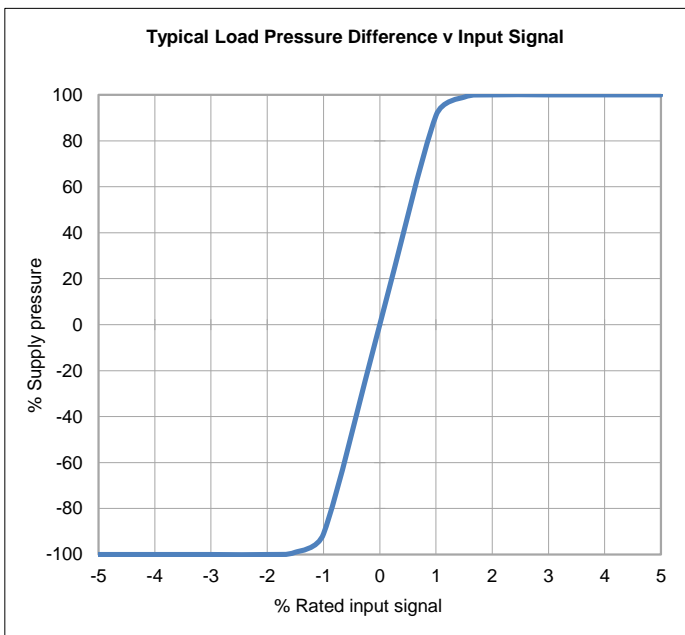
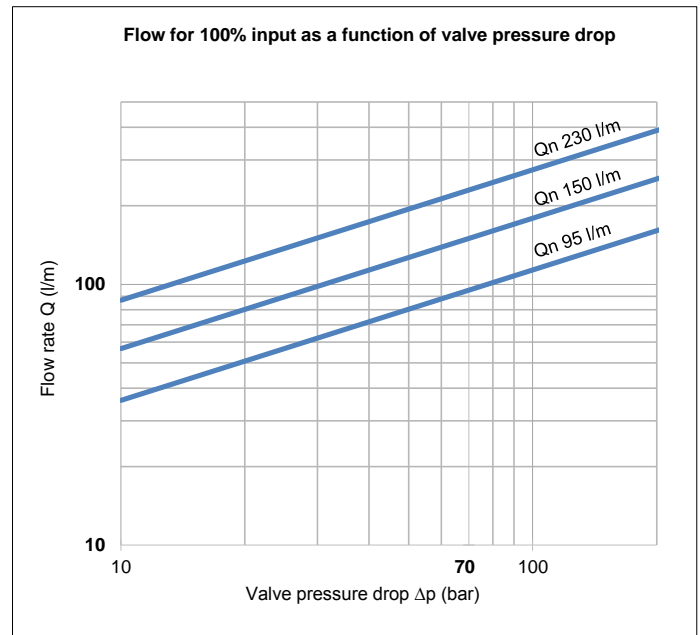
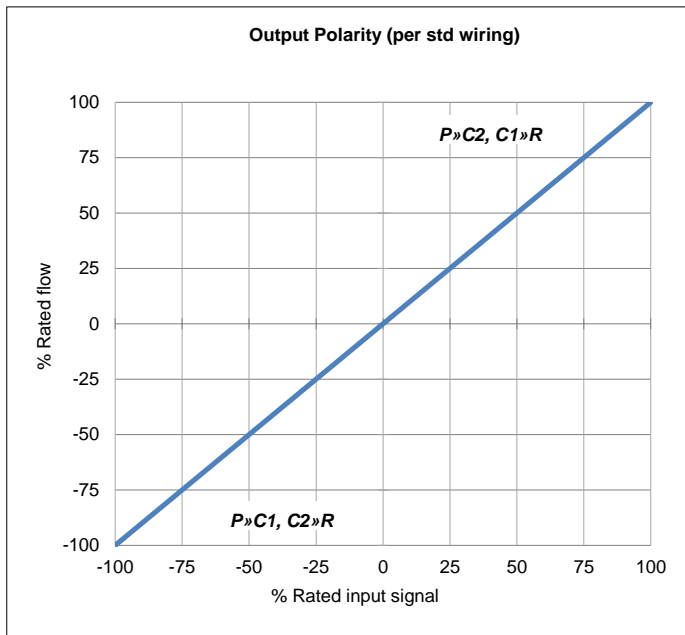

The flow tolerance for standard servovalves is  $\pm 10\%$  of the rated flow at 100% rated input signal.

Rated Signal [In] is the specified input voltage or current of either polarity to produce rated flow. Rated input does not include null bias values.

Rated flow corresponds to the flow at rated input at 10 bar or 70 bar, with no load, therefore in 4-way valves there will be a pressure drop of 5 bar or 35 bar respectively across each land.

Load pressure difference versus input signal indicates typical differential pressure gain between ports C1 (A) and C2 (B) for standard lap spools. Negative and positive overlap change this characteristic significantly.

Internal leakage comprises of tare first stage and laminar leakage between spool and sleeve. With critical lap conditions in 4-way designs the leakage peaks through the null region.

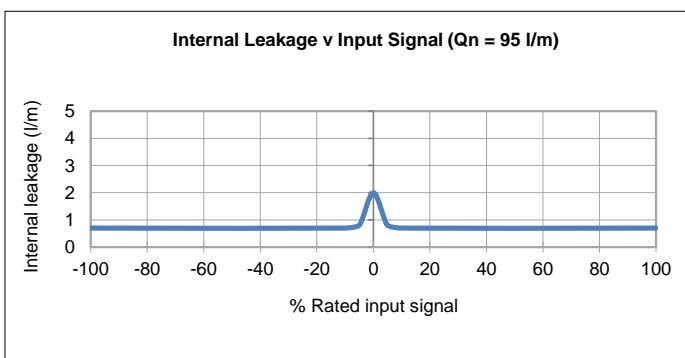

# Technical data

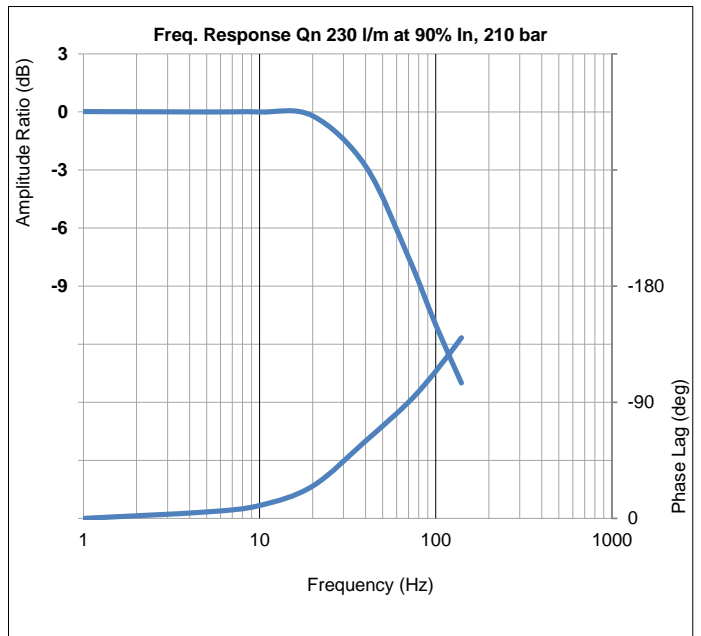
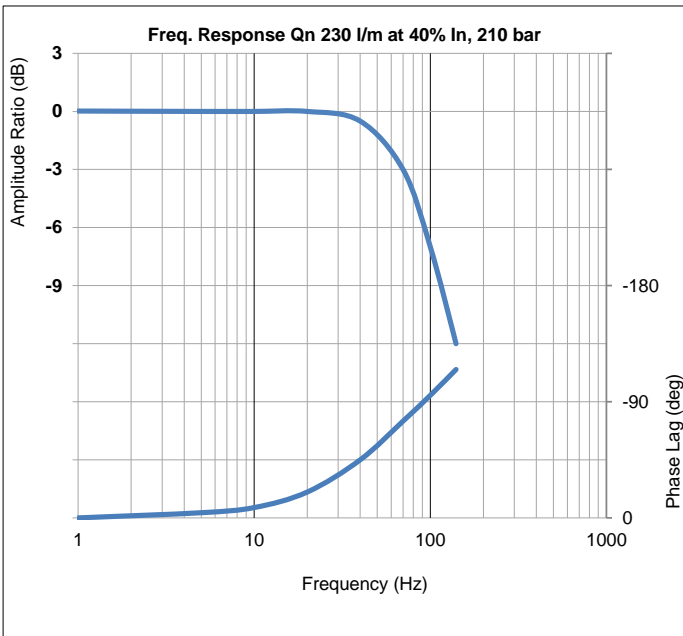
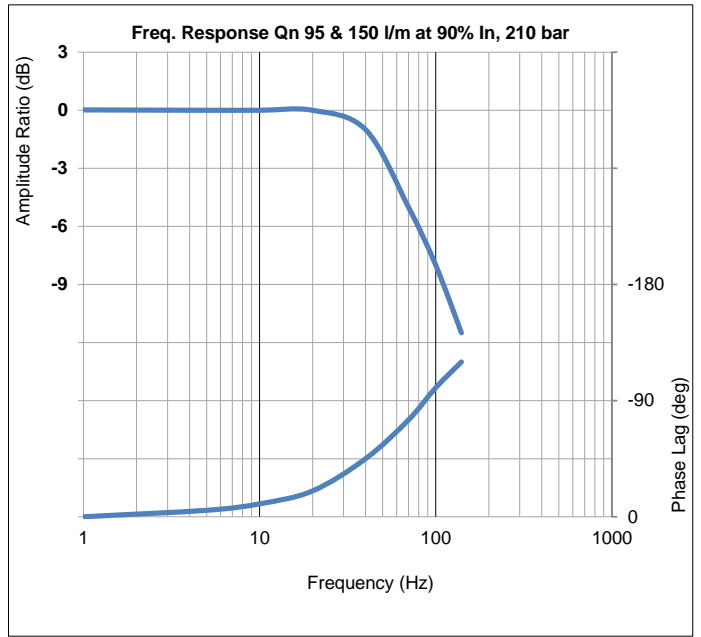
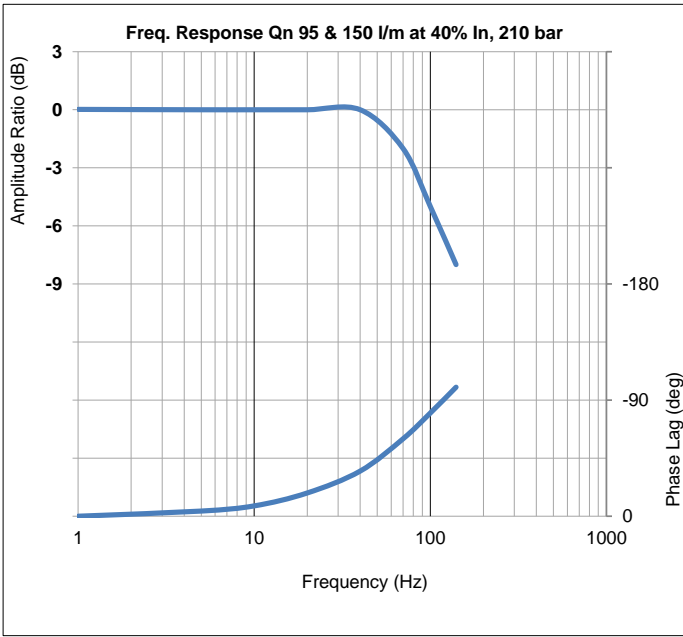

892E series  
INSTALLATION DETAILS



Mounting screws	Skt head cap screws M10 x 55 10.9 ISO 4762
Porting details	P, C1, C2, R ports $\phi 15.8$ , $\square \phi 23.8 \nabla 1.40$ on 50.8 P.C.D. X port $\phi 3$ , $\square \phi 12.7 \nabla 1.40$
Interface seals	Ports P, C1, C2, R - ID 20.35 x $\phi 1.78$ O-Ring Port X - ID 9.25 x $\phi 12.7 \nabla 1.78$ O-Ring
(1) Optional filter housing	Replacement cartridge PN: SRS1479
(2) Null adjust	Remove screw to access potentiometer, rotate using flat blade (2mm) screw driver to remove or apply output stage bias

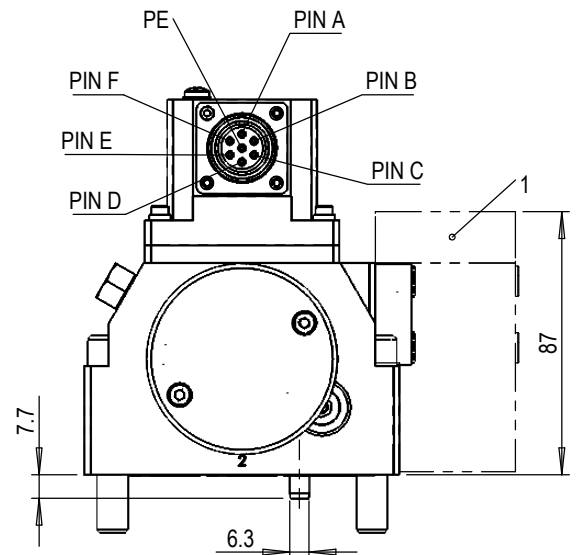
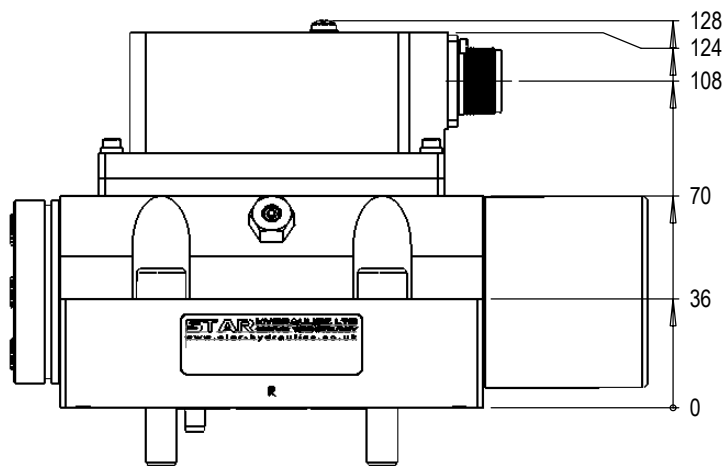
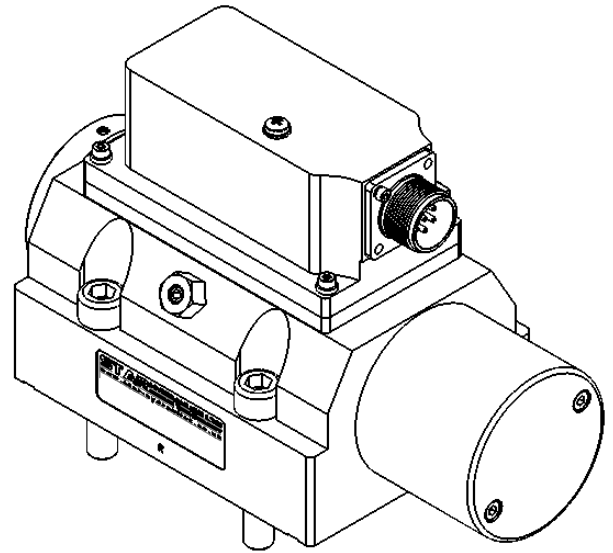
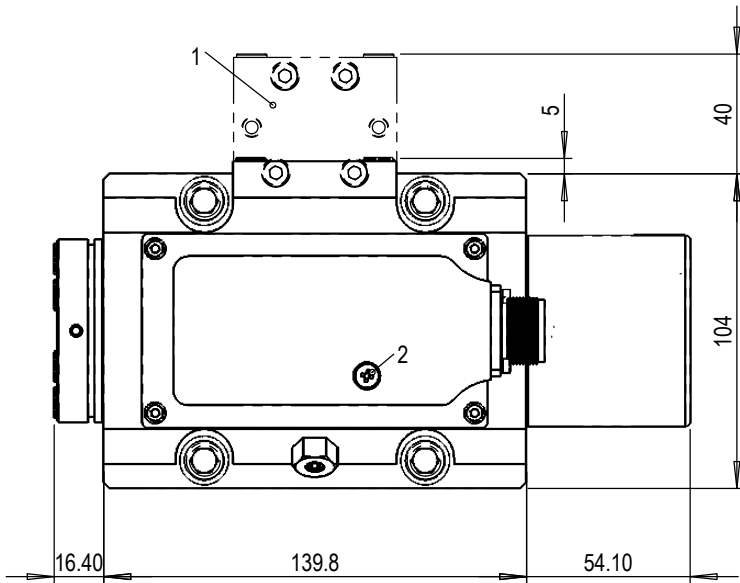

Mounting interface conforms to ISO 10372-06-05-0-92										
	P	C1	C2	R	X	F1	F2	F3	F4	G
size	$\phi 15$	$\phi 15$	$\phi 15$	$\phi 15$	$\phi 3$	M10	M10	M10	M10	$\phi 8 \nabla 9$
x	36.50	11.10	61.93	36.50	55.60	0	73	73	0	11.10
y	17.38	42.80	42.80	68.23	4.60	0	0	85.60	85.60	23.70

Surface flat within 0.01 / 100 : finish better than 0.8  $\mu\text{m}$

